



DELTA

Gelato and pastry display cabinet



your visible value



DELTA

Gelato and pastry display cabinet



your visible value

DELTA

The only professional display cabinet with two 5-litre tray rows in just 80 cm of depth.

To achieve this result, the ISA R&D team patented a new type of side ventilation that allows the depth to be kept to a minimum.

This patented technology makes it possible to differentiate temperatures - with 6 or 4 tray units - for optimal preservation and display of ice creams with various consistencies.



available
R290



DELTA



SIDWARD AIR FLOW
VENTILAZIONE LATERALE

PATENTED TECHNOLOGY

IT

L'unica vetrina professionale a doppia fila di vaschette da 5 lt. in soli 80 cm di profondità. Per raggiungere questo risultato il team R&D ISA ha brevettato un nuovo tipo di ventilazione laterale che permette di minimizzare lo spazio in profondità. Questa tecnologia brevettata consente di differenziare le temperature - a gruppi di 6 o 4 vaschette - per conservare ed esporre al meglio il gelato di diversa consistenza.

FR

La seule vitrine professionnelle à double rangée de bacs de 5 litres en seulement 80 cm de profondeur. Pour atteindre ce résultat l'équipe R&D ISA a breveté un nouveau type de ventilation latérale permettant de minimiser l'espace en profondeur. Cette technologie brevetée permet de différencier les températures, à des groupes de 6 ou 4 bacs, pour conserver et exposer au mieux la glace de différente consistance.

DE

Die einzige professionelle Theke, in der zwei Reihen mit Behältern mit einem Fassungsvermögen von 5 l bei nur 80 cm Tiefe Platz finden.

Um dieses Ergebnis zu erreichen, hat das Team für Forschung und Entwicklung bei ISA eine neue Art der seitlichen Belüftung patentiert, welche es ermöglicht, den Raumbedarf in der Tiefe zu minimieren. Dank dieser patentierten Technologien können Temperaturen - in Gruppen von 6 oder 4 Behältern - unterschieden werden, um Speiseeis mit unterschiedlicher Konsistenz bestmöglich zu lagern und zu präsentieren.

ES

El único expositor profesional con doble fila de bandejas de 5 l en solo 80 cm de profundidad.

Para alcanzar este resultado el equipo de I+D de ISA ha patentado un nuevo tipo de ventilación lateral que permite minimizar el espacio en profundidad. Esta tecnología patentada permite diferenciar las temperaturas, en grupos de 6 ó 4 bandejas, para conservar y exponer de la mejor manera el helado de distinta consistencia.



GELATO

DELTA



DELTA

H 117
P 80
L 130

Gelato&Pastry Dual Temp

	TN	TB	TB/TN	TC	TC/TN	N
	Chiller	Freezer	Dual Temp	Heated	Hot&Cold	Non-refrigerated
RS - Static						
RV - Ventilated			•			
RS/TC S - Static and Dry Heat convertible						
RV/TC S - Ventilated / Dry Heat convertible						
HUR - Meat						
CH - Chocolate						
TC S - Dry Heat						
TC BM - Bainmarie						
N - Non-refrigerated						

DELTA GELATO	Model type	Total display area	Temperature class	Recommended temperature	Energy class	Energy efficiency index	Annual energy consumption	Light source type and class
Height	Length	Superficie espositiva totale m²	Classe di temperatura	Temperatura consigliata °C	Classe energetica	Indice di efficienza energetica EEI	Consumo annuo AEC kWh/A	Tipo e classe illuminazione
H117	120	0,71	G2	-15	C	33,00	5.621	-

Configuration: air cooled plug in unit R290, plexiglass sliding doors closure, led lighting.
Configurazione: motore a bordo ad aria R290, chiusura porte scorrevoli in plexiglass, illuminazione led.



- Installation**
Plug-in
- Configuration**
- Dual Zone (standard)
 - Dual Temp (standard)
- Temperature**
- T1 / -20/+10 °C
 - T2 / -20/+10 °C
- Refrigerant**
R290
- Refrigeration**
Side ventilation (Patented)
- Defrost**
Hot Gas
- Climate class**
4
- Upper glass**
Single heated
- Front glass**
Single heated
- Side glass**
Heated laminated
- Rear closing**
Plexiglass sliding lids
- Service top**
Stainless steel
- Lighting**
Led 5700 K
- Night mode**
Night closing system. Allows the gelato to be perfectly preserved by interrupting the defrost cycle.
- Equipment handling**
- Height-adjustable feet
 - Swivel casters with brake

- Installazione**
Plug-in
- Configurazione**
- Dual Zone (standard)
 - Dual Temp (standard)
- Temperatura**
- T1 / -20/+10 °C
 - T2 / -20/+10 °C
- Refrigerante**
R290
- Refrigerazione**
Ventilazione laterale (Patented)
- Sbrinamento**
Gas caldo
- Classe climatica**
4
- Vetro superiore**
Singolo riscaldato
- Vetro frontale**
Singolo riscaldato
- Vetri laterali**
Stratificati riscaldati
- Chiusura posteriore**
Scorrevoli in plexiglas
- Piano di servizio**
Acciaio inox
- Illuminazione**
Led 5700 K
- Night mode**
Sistema di chiusura notturna. Permette di conservare il gelato perfettamente grazie all'interruzione del ciclo di sbrinamento.
- Movimentazione**
- Piedini regolabili in altezza
 - Ruote pivotanti con freno

T1 | T2
Dual zone

Dual Zone

It is possible to differentiate the temperatures (maximum two zones) for optimal preservation and display of ice cream with different consistencies.

È possibile differenziare le temperature (massimo due zone) per conservare ed esporre al meglio il gelato di diversa consistenza.



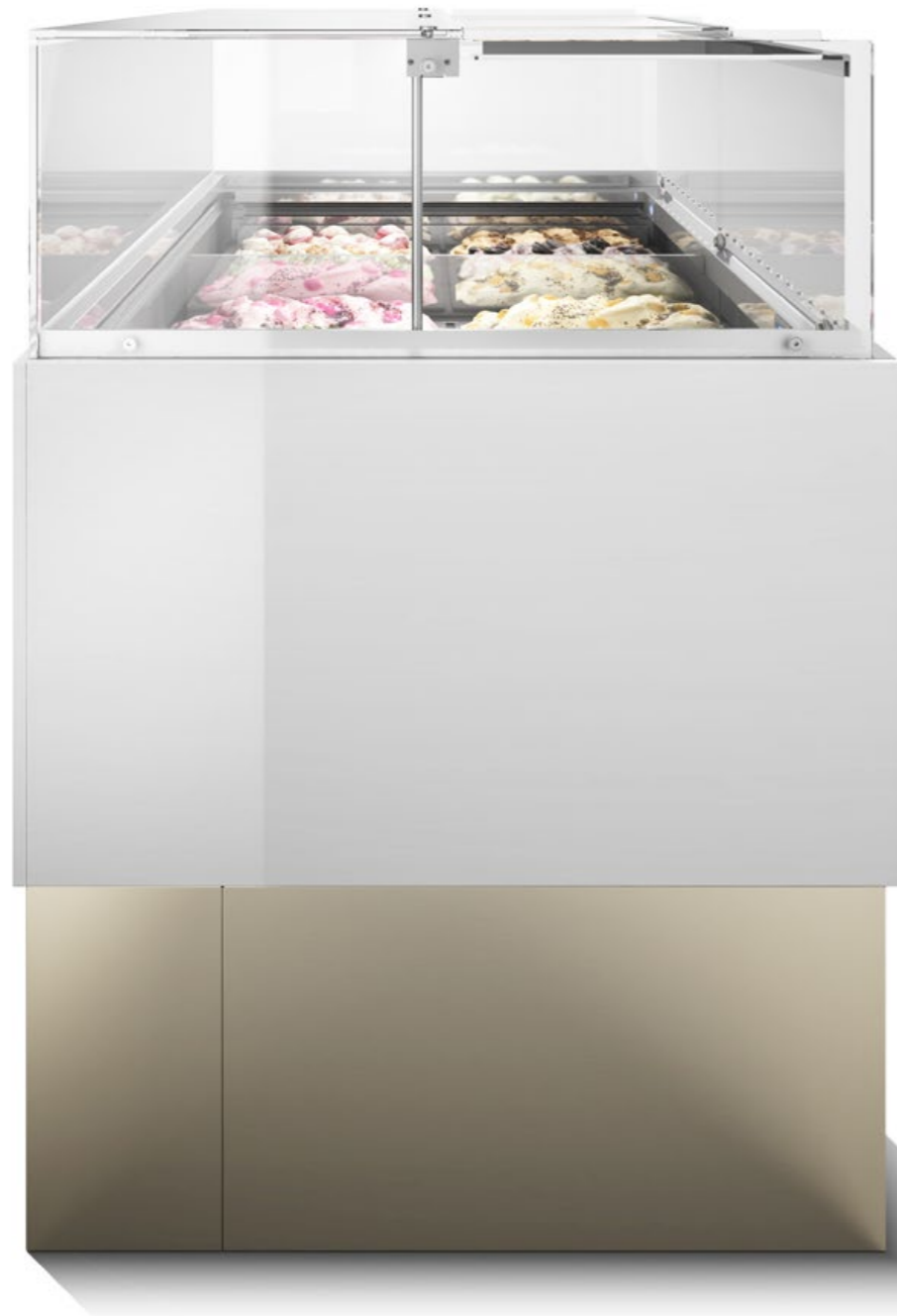

← 80 cm →

Gelato Style	Gelato	•
	Ice cream sticks Stecchi	•
	Single portions Monoporzioni	•
	Frozen pastry Pasticceria fredda	•
Performance	Evaporators Evaporatori	2
	Air outlet Mandata d'aria	2
	Inclination of the display Inclinazione del piano espositivo	0°
	Climate Class / Classe climatica 4 - 30 °C / 55 %RH	•
	Air out deflectors / Deflettori uscita aria	Fixed Fissi
Setup Allestimento	Container / Vaschetta 5 Lt. 360x165x120h	•
	Container / Vaschetta 7 Lt. 360x165x150h	•
	Container / Vaschetta 5 Lt. 360x250x80h	•
	Container / Vaschetta 10 Lt. 360x250x120h	•
	Container / Vaschetta 12 Lt. 360x250x150h	•
	Ice cream stick container / Vaschetta stecchi 360x250x43h	•
	Single portions container / Vaschetta monoporzioni 360x250x43h	•
	Pastry trays / Vassoi pasticceria	Separate / Separati



Night mode

Night closing system
Allows the gelato to be perfectly preserved by interrupting the defrost cycle.

Sistema di chiusura notturna
Permette di conservare il gelato perfettamente grazie all'interruzione del ciclo di sbrinamento.



Dual Zone

It is possible to differentiate the temperatures (maximum two zones) for optimal preservation and display of ice cream with different consistencies.

È possibile differenziare le temperature (massimo due zone) per conservare ed esporre al meglio il gelato di diversa consistenza.



SIDE AIR FLOW
VENTILAZIONE LATERALE
PATENTED TECHNOLOGY



available
R290





130

External dimensions (LxDxH) Dimensioni esterne (LxPxH)	1276 x 831 x 1170 / 1229 mm
Capacity (gross/net) Capacità (lorda/netta)	180 / 130 lt
Net weight Peso netto	150 kg
Refrigeration Refrigerazione	Ventilated - Ventilata
Refrigerant Refrigerante	R290 (Plug-in) R404A (Remote optional)
Climate class Classe climatica	4
Operating conditions Condizioni ambientali	30 °C / 55 %RH
Temperature range Temperatura di regolazione	-20/+2 °C
Product temperature Temperatura prodotto	-16/-14 °C
Compressor (type) Compressore (tipologia)	2 Hermetic - 2 Ermetici
Defrost Sbrinamento	Hot gas - Gas caldo (R290) Reverse cycle - Inversione di ciclo (R404A)
Power supply Alimentazione	230 V / 1 Ph / 50 Hz
Electrical input (nominal) Assorbimento elettrico (regime)	1350 W / 7,4 A
Electrical input (defrost) Assorbimento elettrico (sbrinamento)	1240 W / 6,6 A

Technical sheet about models whit condensing unit included with air cooled
Dati tecnici riferiti a modelli con unità a bordo con condensazione ad aria.





Setup

Allestimento

5 Lt 360x165x120hx150h		12 (6+6)
5 Lt 360x250x80hx120hx150h		8 (4+4)
Tray Vassoio		4 (2+2)
Ice cream stick container Vaschetta stecchi		8 (4+4)
Single portions container Vaschetta monoporzioni		8 (4+4)





Available colours - Colori disponibili

Front panel (1) - Side panels (3)
Pannello frontale (1) - Fianchi laterali (3)

-  RAL 9003
-  RAL 9005
-  RAL 7022
-  RAL on demand

● Standard / Di serie

Basement (2) - Side basement (4)
Basamento (2) - Basamenti laterali (4)

-  Bronze
-  RAL 9003
-  RAL 9005
-  RAL on demand

● Standard / Di serie

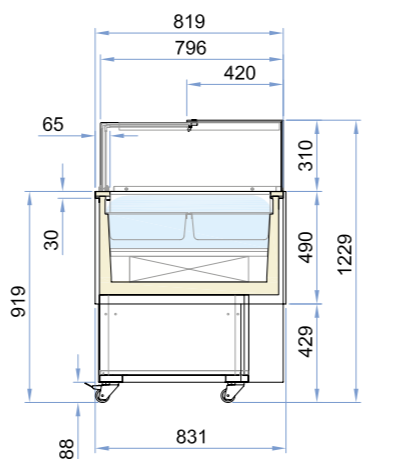
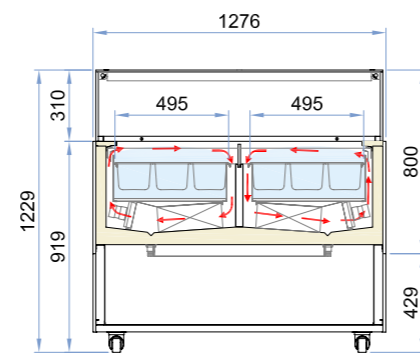
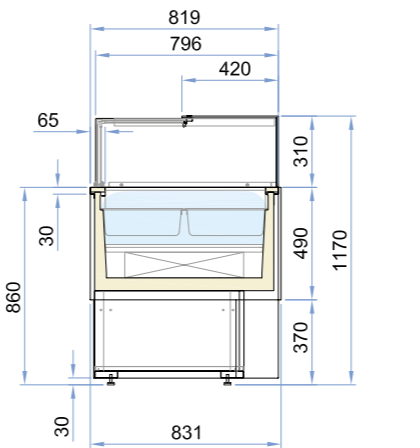
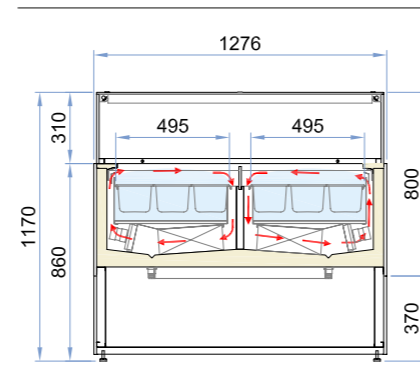



ISA S.p.A.

via Madonna di Campagna 123
06083 Bastia Umbra (PG)
Italy

T. +39 075 801 71

F. +39 075 800 09 00

E. customerservice@isaitaly.com

www.isaitaly.com

